

# KS-PS Addressable SmartOne® Protocol Photoelectric Smoke Detector

## FEATURES

- *Multi-criteria optical smoke sensing technology*
- *Advanced data analysis reduces chance of nuisance alarms*
- *Compatible with Kidde®, Fenwal® and Chemetron® intelligent control units*
- *Works with SmartOne® communication protocol*
- *Operates in conjunction with legacy SmartOne DS, PSD, CPD and THD smoke and heat detectors*
- *Two-color (green/red) status LED*
- *Supports remote LED alarm indication*
- *Detector head and terminal base design (bases sold separately)*
- *Low-profile design blends into ceiling*
- *Suitable for raised floor and plenum applications*
- *Attractive 6 in. diameter trim ring provided with bases*
- *Electronic addressing performed with SmartOne Hand-Held Programmer*
- *FM Approved*
- *cULus Listed to UL268, 7th edition*
- *California State Fire Marshal Listed*

## DESCRIPTION

The KS-PS Photoelectric Smoke Detector is an intelligent device that gathers analog information from multiple optical sensors, converting this data into digital signals. Utilizing dual optical wavelengths combined with multiple detection angles, the KS-PS differentiates particles that are not representative of actual smoke. Data is digitally filtered to remove signal patterns that are typical of nuisance sources, thus reducing unwanted alarms. To make an alarm decision, the detector's on-board microprocessor measures and analyzes all optical sensor readings and compares this information to a preprogrammed setting.

## ADDRESSING

KS-PS detectors feature electronic addressing. No addressing switches are used.

## PROTOCOL

This product will operate only on a Kidde Fire Systems fire alarm-suppression control unit employing SmartOne communications protocol.

## STATUS LED

KS-PS detectors use an LED to indicate the detector's condition. In normal, standby condition, a green LED flashes at a 9 second repetition rate. An alarm is indicated by a red flash at a 2.50 second repetition rate.

## REMOTE ALARM LED

An optional SIGA-LED Remote Indicator can be connected to the standard DS-SB base if the KS-PS detector status LED is in a location where it cannot be easily viewed.



## INSTALLATION

A KS-PS detector mounts to North American 1-gang boxes, 3-1/2 inch or 4 inch octagon boxes, and to 4 inch square electrical boxes 1-1/2 inches (38 mm) deep.

## EASY TWIST HEAD

A KS-PS detector head is installed onto its base by aligning arrow marks and gently twisting the head clockwise until secure. Removal is just as easy and is done by grasping the head and gently pressing down while turning counter-clockwise. Removal can be aided with the optional SIGA Removal Tool (P/N SIGA-RTA). This tool can be attached to a telescoping pole to avoid the use of ladders.

## SENSITIVITY



The alarm sensitivity is the minimum obscuration level at which the detector initiates an alarm condition and can be specified via the control unit menus or the remote configuration software. The control unit to which the detectors are connected is capable of interrogating each detector to determine its sensitivity.

## DETECTOR BASES

The KS-PS detector head attaches easily to these compatible bases. Detector bases have wiring terminals that are accessible from the “room-side” after mounting the base to the electrical box. A trim ring is supplied with the 4-inch base to help hide surface imperfections.

- **Model DS-SB Standard Base:** Connects the detector to the Signaling Line Circuit (SLC).
- **Model DS-RB Relay Base:** Connects the detector to the Signaling Line Circuit (SLC) and provides optional Relay functionality to the KS-PS detector.

## ORDERING INFORMATION

KS-PS	Intelligent Photoelectric Smoke Detector, head only 
DS-SB	Detector Mounting Base, 4 in. diameter, with 6 in. trim ring, for 2-wire connection to SmartOne SLC 
DS-RB	Detector Mounting Base, 4 in. diameter, with relay option and 6 in. trim ring, for 2-wire connection to SmartOne SLC 
SM200-12PKG	Canned smoke for functional testing of smoke detectors, package of 12
SIGA-LED	Optional Remote Alarm LED
SIGA-VA	Detector Vacuum Attachment
SIGA-RTA	Detector Removal Tool Attachment

## TECHNICAL SPECIFICATIONS

Operating voltage	24 VDC (nominal)
Current Normal Operating Alarm	150 $\mu$ A 220 $\mu$ A
SLC Protocol	SmartOne
UL/cUL smoke sensitivity range	0.5 to 3.50 %/ft. (2.95 to 11.48%/m) obscuration (Open Area Use Only)
NOTE: Smoke sensitivity is selected at the control unit or with the remote configuration software. Default values are 2.0%/ft (Alarm) and 1.5%/ft (Pre-Alarm). Refer to the Installation, Operation and Maintenance Manual or the Configuration Software User Guide for your system.	
North American standards	UL 268 (7th edition), UL 268A, CAN/ULC-S529, FM Approvals 3210
Compliances: <ul style="list-style-type: none"> <li>• This device complies with Part 15, Class A of the FCC Rules. Operation is subject to the following two conditions: (1) This device may not cause harmful interference, and (2) this device must accept any interference received, including interference that may cause undesired operation.</li> <li>• ICES-003, Class A</li> <li>• EN 55011, Class A</li> <li>• AS/NZS CISPR 11, Class A</li> </ul>	
Air velocity	0 to 4,000 ft./min (0 to 20.32 m/s)
Compatible bases	DS-SB (Standard), DS-RB (Relay)
Wall mounting: distance from ceiling	12 in. (305 mm) max.
Operating Environment Temperature Relative humidity	32 to 120°F (0 to 49°C) 0 to 93% non-condensing
Storage temperature	-4 to 140°F (-20 to 60°C)
Environmental compensation	Automatic
Color	White head and base
Construction	High impact engineering polymer
Mounting	Plug-in

## INTEGRATION OF DETECTORS

KS-PS detectors can be mixed in any order with SmartOne legacy detectors on a Kidde Fire Systems intelligent control unit running SmartOne protocol.

## COMPATIBLE CONTROL UNITS

Fire Alarm Control Unit (FACU) Type	Current Product	Legacy Product
Single Loop	ARIES®-SLX	ARIES FenwalNET™ 6000 MICRO SLX PEGAsys™* FenwalNET 2000*
Multiple Loop	ARIES®-MLX	ARIES NETLink FenwalNET 8000-ML MICRO MLX PEGAsys* FenwalNET 2000*

\* FACUs running software revision 82.4 are compatibility-tested but not agency listed with the device(s) in this data sheet.

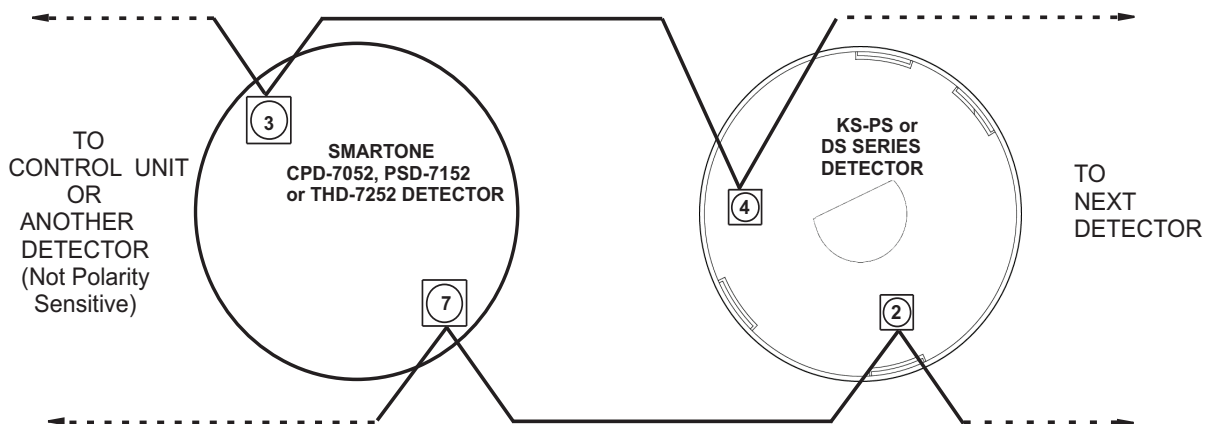
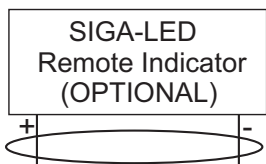

Figure 1: Combining Legacy Detectors with KS Series Detectors  
(Class B Wiring Style Shown)

### NOTES:

1. Detectors are not polarity sensitive. Terminals 3 and 7 (SmartOne legacy detectors) or Terminals 2 and 4 (KS or DS Series detectors) can be reversed.
2. Detectors can be installed in any order.
3. SLC loop is not sensitive to the location of the control unit (can be left or right end of loop).
4. Four-wire loops will be wired as shown, bringing loose end of loop back to the control unit.



NOTE: Maximum wiring resistance to SIGA-LED must not exceed 10 Ohms (per wire).

**TERMINAL DESIGNATIONS:**

Number	Description
1	Not used
2	SLC IN/OUT
3	Not used
4	SLC IN/OUT
5	Remote LED +
6	Not used
7	Remote LED -

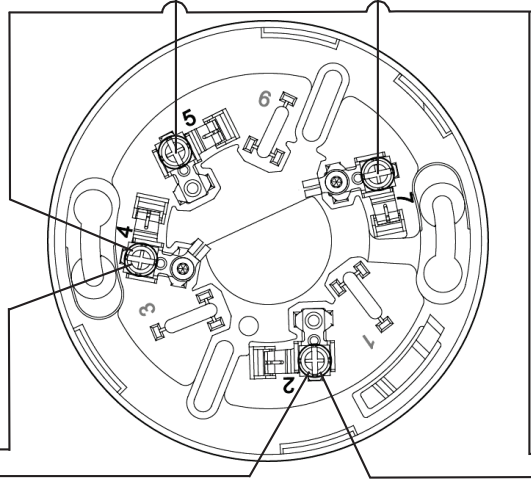

From control unit  
or  
From previous detector

To next detector

**DS-SB Standard Base**  
(Shown with Class B Wiring and Optional Remote LED)

**TERMINAL DESIGNATIONS:**

Number	Description
1	Normally Open
2	SLC IN/OUT
3	Common
4	SLC IN/OUT
5	Not used
6	Normally Closed
7	Not used

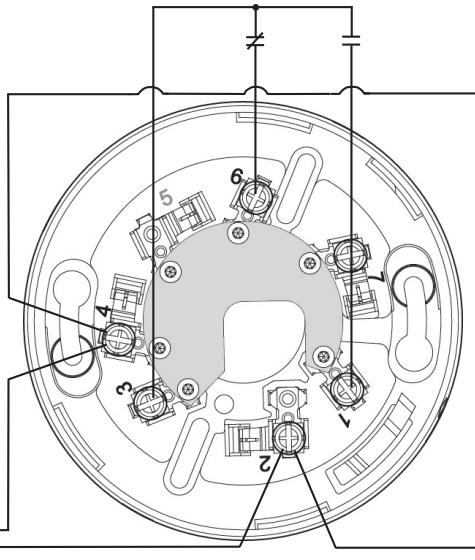

From control unit  
or  
From previous detector

To next detector

**DS-RB Standard Base**  
(Shown with Class B Wiring)

**EXPORT INFORMATION (USA)**

Jurisdiction: EAR  
US ECCN: EAR99  
This document contains technical data subject to the EAR.

Kidde, Fenwal, Chemetron, and SmartOne are registered trademarks of Kidde-Fenwal, Inc., or its parents, subsidiaries or affiliates.

This literature is provided for informational purposes only. KIDDE-FENWAL, INC. believes this data to be accurate, but it is published and presented without any guarantee or warranty whatsoever. KIDDE-FENWAL, INC. assumes no responsibility for the product's suitability for a particular application. The fire suppression system design, installation, maintenance, service and troubleshooting must be performed by trained, authorized Kidde Fire Systems distributors for the product to work correctly. If you need more information on this product, or if you have a particular problem or question, contact: KIDDE-FENWAL, INC., Ashland, MA 01721 USA, Telephone: (508) 881-2000.



K-71-101 Rev AA  
©2020 Carrier

Kidde Fire Systems  
400 Main Street  
Ashland, MA 01721  
Ph: 508.881.2000  
Fax: 508.881.8920  
www.kiddefiresystems.com